

The GaGe Razor™ family of multi-channel digitizers features up to 4 channels in a single-slot PCI Express or PCI card with up to 200 MS/s sampling per channel, and up to 16 GS of on-board acquisition memory.

Combine several Razor cards for up to 32 channels in a single system.

APPLICATIONS

Radar Design and Test
Disk Drive Testing
Manufacturing Test
Signal Intelligence
Lidar Systems
Communications
Non-Destructive Testing
Spectroscopy
High-Performance Imaging
Ultrasound Test

Razor CompuScope 16XX

16-Bit Family of Multi-channel Digitizers for the PCI Express and PCI Bus



The Razor family of 16-bit digitizers provides 16-bit performance at high speed and high channel density on a PCI Express or PCI platform.

FEATURES

- 2 or 4 digitizing channels
- 100 or 200 MS/s maximum sampling per channel
- 16 bits vertical resolution
- 128 MS to 16 GS on-board acquisition memory
- 65 or 125 MHz bandwidth
- Ultralow distortion (THD < -80 dB)
- Full-size, single-slot PCI Express or PCI card
- Full-featured front-end, with software control over input ranges, coupling and impedances
- Dual-port memory and Data Streaming at up to 3.1 GB/s on PCI Express models
- 32 bits, 66 MHz PCI standard for 200 MB/s transfer to PC memory
- Ease of integration with External or Reference Clock In and Clock Out, External Trigger In and Trigger Out
- Programming-free operation with GageScope® oscilloscope software
- Software Development Kits available for LabVIEW, MATLAB, C/C#
- Custom FPGA firmware available

MAIN RAZOR SPECIFICATIONS

Razor Model	Number of Input Channels	Maximum Sampling Rate	Input Bandwidth (-3 dB Point)
CS1621	2 Simultaneous	100 MS/s	65 MHz
CS1641	4 Simultaneous	100 MS/s	65 MHz
CS1622	2 Simultaneous	200 MS/s	125 MHz
CS1642	4 Simultaneous	200 MS/s	125 MHz

Vertical Resolution: 16-bits
 Basic Acquisition Memory¹: 128 MegaSamples
 Available Acquisition Memory Options: 256 MS, 512 MS, 1 GS, 2 GS (PCI models)
 1 GS, 2 GS, 4 GS, 8 GS, 16 GS (PCI Express models)

CHANNEL SPECIFICATIONS

Channel Input Voltage Ranges: (software-selectable) 1 M Ω : ± 100 mV, ± 200 mV, ± 500 mV, ± 1 V, ± 2 V, ± 5 V, ± 10 V, ± 20 V, ± 50 V
 50 Ω : ± 100 mV, ± 200 mV, ± 500 mV, ± 1 V, ± 2 V, ± 5 V

Channel Impedance: 1 M Ω or 50 Ω (software-selectable)

Channel Impedance Accuracy: 0.5% for 1 M Ω . 1.5% for 50 Ω (typical)

Channel Capacitance (1 M Ω): 65 pF on ± 100 mV, ± 200 mV
 45 pF on ± 500 mV, ± 1 V, ± 2 V, ± 5 V
 35 pF on ± 10 V, ± 20 V, ± 30 V

Channel Coupling: AC or DC (software-selectable)

Channel DC User Offset²: Spans Full Scale Input Range (FSIR) (software-selectable)

Channel Low-Pass Filter: 3-Pole with -3dB point at 25 MHz
 (May be independently software-selected for each input channel)

Channel-to-Channel Isolation: TBA

Channel Absolute Max Input: 50 Ω : ± 15 V
 1 M Ω : ± 75 V (except on ± 100 mV and ± 200 mV range, where Max is ± 25 V)

¹ Memory is divided among the all active Razor channels (1, 2 or 4)

² Adjustable in 1/2 % steps. Above ± 5 V is limited to ± 2.4 V

Razor CompuScope 16XX Simplified Block Diagram

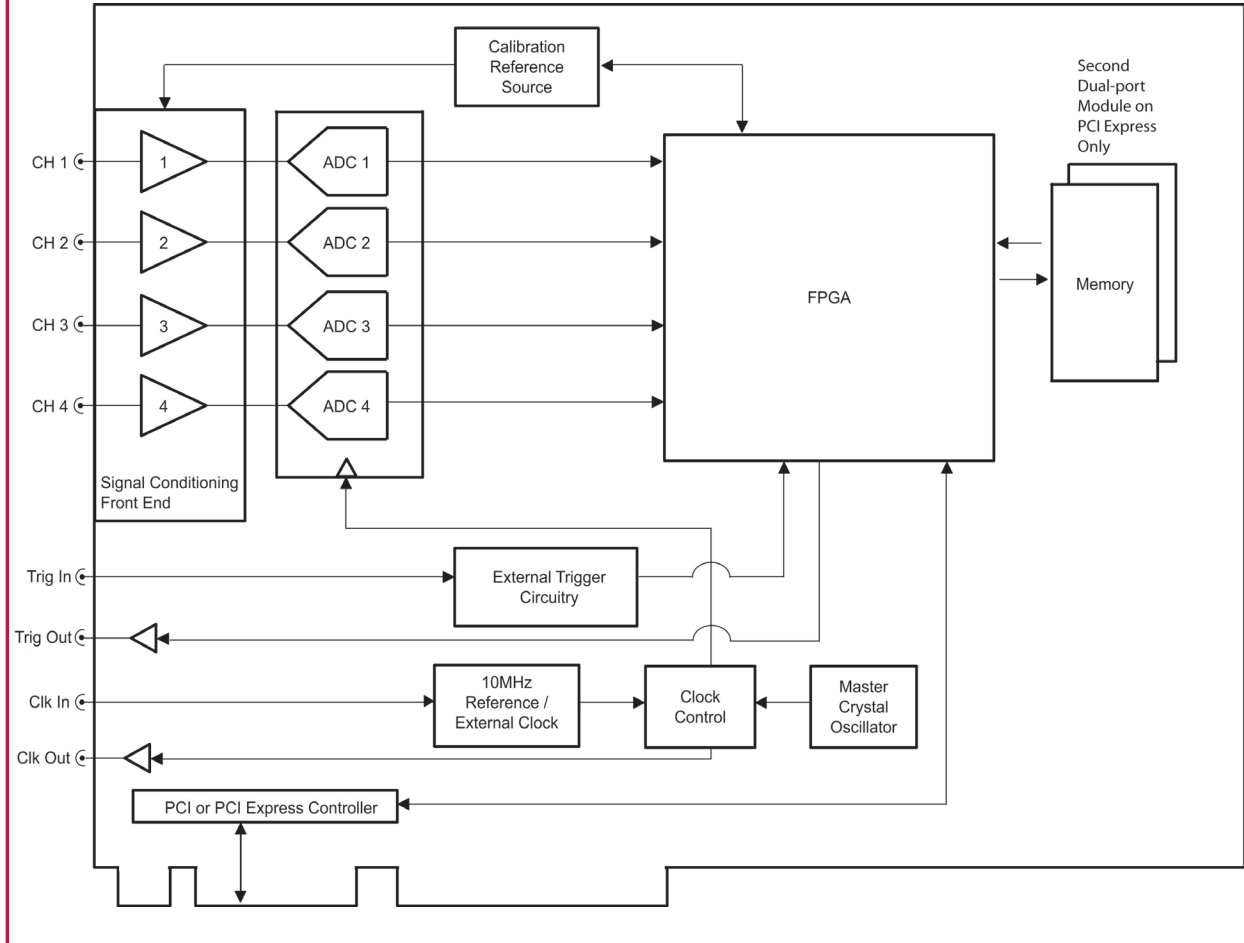

PHYSICAL/MECHANICAL

Length: 312.00 mm / 12.283"
 Width: < 12.5 mm/0.5"
 (neighboring PCI slots are accessible)
 Height: 106.68 mm / 4.200"
 Weight: < 0.45 Kg / 1 lbs
 Connectors: SMA

Bus Width: 32-bits 8 Lanes
 Bus Speed: 66 MHz or 33 MHz 40 Gb (Gen2) or 20 Gb (Gen1)
 Bus Throughput: 200 MB/s to PC memory (66 MHz PCI; dependent on motherboard and configuration) 3.1 GB/s (Gen2) or 1.6 GB/s (Gen1)

BUS INTERFACE

	(PCI)	(PCI Express)
Plug-&-Play	Fully supported	Fully supported
Bus Mastering	Fully supported	Fully supported
Scatter-Gather:	Fully supported	Fully supported

Compatibility: PCI-compliant, v.2.2. Also v.2.1 systems that supply 3.3 V to PCI slot
 PCI Express 2.0 compliant (Also 1.1 at 20 Gb)

CHANNEL FREQUENCY RESPONSE

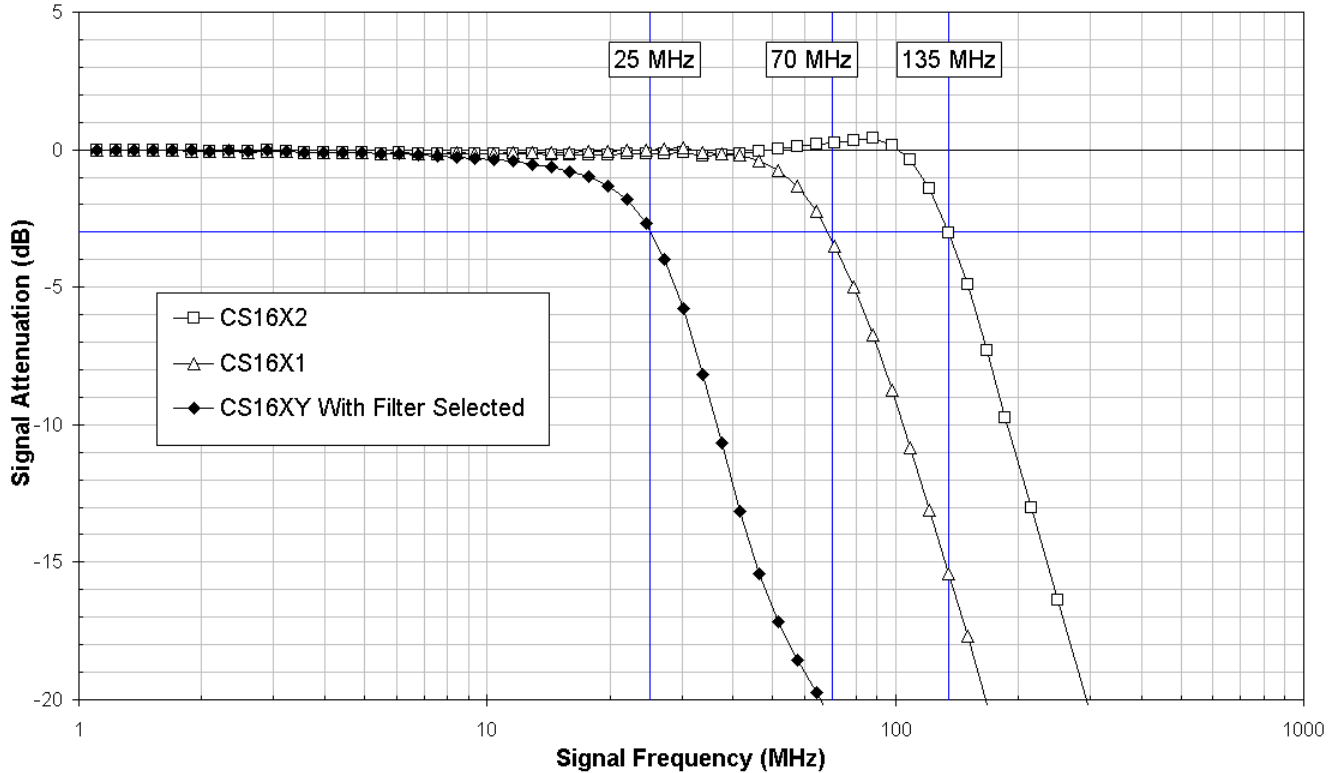

Note: Typical Frequency Response curves above taken on ± 500 mV input range with on with 50Ω termination with DC coupling. In AC Coupled mode, the lower -3 dB cutoff frequency is 200 kHz.

Input Range	CS16X1				CS16X2			
	Bandwidth (MHz)		Flatness (MHz)		Bandwidth (MHz)		Flatness (MHz)	
	50 Ω	1 M Ω	50 Ω	1 M Ω	50 Ω	1 M Ω	50 Ω	1 M Ω
± 2 V	70.1	69.4	56.7	59.2	133.8	69.3	110.0	59.3
± 500 mV	70.6	68.2	57.4	58.2	135.2	68.2	111.6	58.2
± 100 mV	69.5	62.0	55.9	46.2	132.0	62.0	107.6	46.2

Note¹: The *Bandwidth* is defined as frequency at which the signal attenuation falls below -3 dB of its value at DC. The *Flatness* is the frequency below which the signal attenuation is constant within ± 1 dB of its value at a 1 MHz signal frequency.

Rise Time²:
 5.0 nanoseconds for CS16X1 (Typical on 50Ω)
 2.6 nanoseconds for CS16X2 (Typical on 50Ω)

1 In AC coupling mode with 1 M Ω termination, lower -3dB roll-off is at 10 Hz
 2 The Rise Time is calculated as $0.35/\text{Bandwidth}$

CHANNEL ABSOLUTE ACCURACY

DC Gain and Offset Error are presented as a function of the Full-Scale Input Range (FSIR). For example, on the ± 1 Volt Input Range, the FSIR is 2 Volts.

Absolute DC Gain Error (Volts): < $\pm 0.3\% \times (\text{FSIR})$ (50 Ω)
 < $\pm 0.1\% \times (\text{FSIR})$ (1M Ω)
 e.g. Gain Error < $0.3\% \times 2\text{V} = 6 \text{ mV}$ on $\pm 1 \text{ V}$ Input Range (50 Ω)

Absolute DC Offset Error (Volts): < $\pm (0.2\% \times (\text{FSIR}))$ (50 Ω)
 < $\pm (0.2\% \times (\text{FSIR}))$ (1M Ω)
 e.g. < $0.2\% \times 2\text{V} = 4 \text{ mV}$ on $\pm 1 \text{ V}$ Input Range (50 Ω)

Notes:

The Maximum Absolute DC Error may be calculated by summing the Absolute DC Gain Error and the Absolute DC Offset Error in quadrature

Maximum Absolute DC Error = $\sqrt{(\text{Absolute DC Gain Error})^2 + (\text{Absolute DC Offset Error})^2}$
For example, on the ± 1 Input Range (50 Ω)

Maximum Absolute DC Error = $\sqrt{(0.3\% \times 2\text{V})^2 + (0.2\% \times 2\text{V})^2}$

Maximum Absolute DC Error < 7.2 mV

Maximum Absolute DC Error < 0.36% of FSIR

These values relate only to the Absolute accuracy of the Razor CompuScope and say nothing about the relative accuracy. Relative accuracy performance is superior and is provided by the Dynamic Performance Parameters.

Each time that a new input configuration (e.g. Input range, termination, coupling) is selected, the Razor undergoes an on-board auto-calibration sequence, which corrects for component value changes due to aging or thermal drift.

Before shipment, all Razor CompuScopes are tested at the factory using the Gage Performance Verification System. This system introduces DC voltages from a NIST-traceable calibrator source to the card in all input configurations and confirms that no measured errors are worse than the errors listed above.

RAZOR DYNAMIC PERFORMANCE

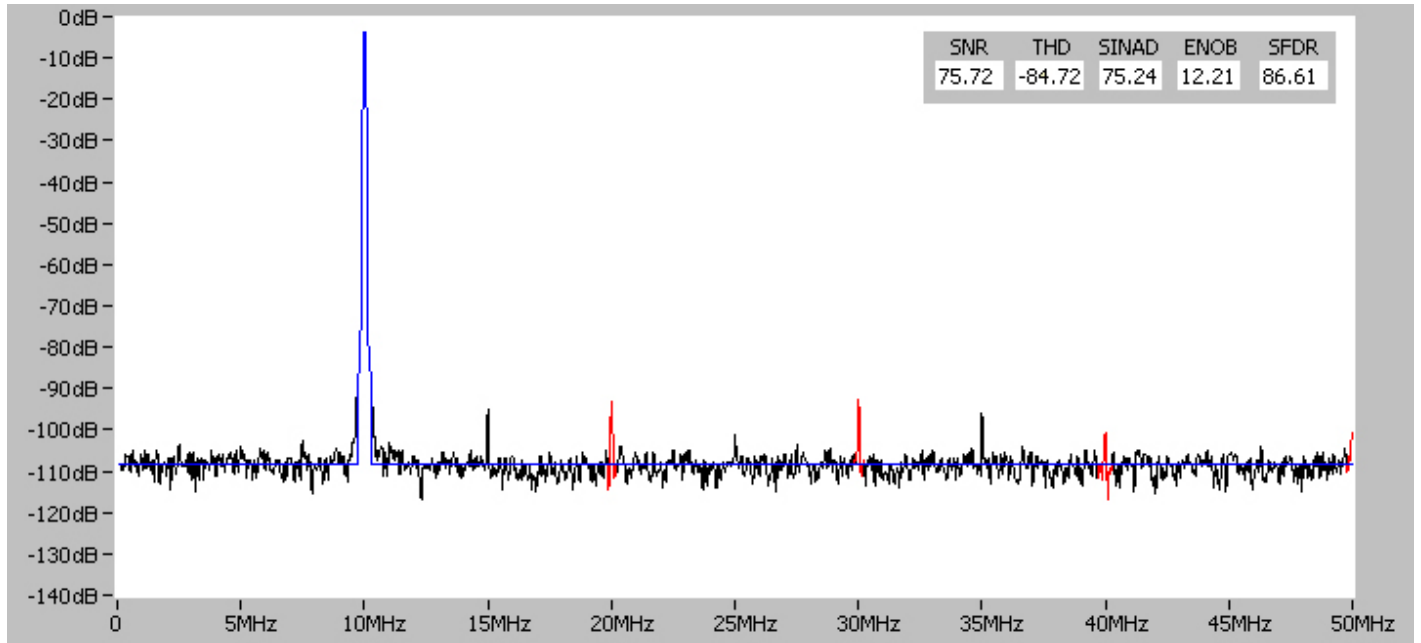

Frequency spectrum above taken on a Razor CS1641 on its ± 500 mV input range with 50Ω termination and DC coupling.

Dynamic Parameters are measured by acquiring a high-purity 10 MHz sine wave signal, deriving an associated Fourier Spectrum and identifying the Fundamental Power (F), the Noise Power (N) and the Harmonic Power (H). These Powers are measured as the areas under the frequency bins respectively indicated in blue, red and black in the frequency spectrum above.

DYNAMIC PARAMETERS DEFINITIONS

Signal-to-Noise Ratio (SNR) $\equiv 10 \times \log (F/N)$

Total Harmonic Distortion (THD) $\equiv 10 \times \log (H/F)$

Signal-to-Noise-and-Distortion Ratio (SINAD) $\equiv 10 \times \log (F/(H+N))$

Effective Number Of Bits (ENOB) $\equiv (SINAD - 1.76 \text{ dB})/6.02 \text{ dB}$

Spurious Free Dynamic Range (SFDR) \equiv Amplitude of highest spurious spectral peak

RMS Noise \equiv Standard Deviation of acquired signal with CompuScope input loaded with external 50Ω terminator. No filters are applied.

Razor Dynamic Parameters with 10 MHz Signal Frequency¹

Product	Input Range	SNR		THD		SINAD		ENOB		SFDR	
		50 Ω	1 MΩ	50 Ω	1 MΩ	50 Ω	1 MΩ	50 Ω	1 MΩ	50 Ω	1 MΩ
CS16X1	±500 mV	75.72 dB	62.31 dB	-84.72 dB	-66.65 dB	75.24 dB	61.03 dB	12.21	9.85	86.61 dB	67.55 dB
	±100 mV	70.99 dB	62.45 dB	-82.78 dB	-65.70 dB	70.74 dB	60.90 dB	11.50	9.82	85.02 dB	66.44 dB
CS16X2	±500 mV	73.03 dB	62.22 dB	-80.96 dB	-66.69 dB	72.43 dB	60.99 dB	11.74	9.84	86.61 dB	68.64 dB
	±100 mV	69.04 dB	62.06 dB	-78.31 dB	-66.20 dB	68.60 dB	60.75 dB	11.18	9.80	83.65 dB	67.77 dB

Razor Dynamic Parameters with 70 MHz Signal Frequency¹

Product	Input Range	SNR		THD		SINAD		ENOB		SFDR	
		50 Ω	1 MΩ	50 Ω	1 MΩ	50 Ω	1 MΩ	50 Ω	1 MΩ	50 Ω	1 MΩ
CS16X1	±500 mV	69.78 dB	56.82 dB	-60.21 dB	-52.39 dB	60.09 dB	51.35 dB	11.30	7.15	61.91 dB	52.22 dB
	±100 mV	62.86 dB	56.36 dB	-60.10 dB	-52.54 dB	58.50 dB	51.33 dB	10.15	8.23	61.54 dB	52.67 dB
CS16X2	±500 mV	68.84 dB	53.93 dB	-68.20 dB	-47.45 dB	65.71 dB	46.91 dB	10.62	7.50	71.47 dB	47.77 dB
	±100 mV	57.83 dB	53.21 dB	58.79 dB	-48.30 dB	35.44 dB	47.99 dB	8.92	7.68	60.54 dB	48.53 dB

RMS Noise on Select Input Ranges

Input Range	±100 mV		±500 mV		±2 V		±10 V		±50 V	
Razor Model	50 Ω	1 MΩ	50 Ω	1 MΩ	50 Ω	1 MΩ	50 Ω	1 MΩ	50 Ω	1 MΩ
CS16X1	30 μV	100 μV	60 μV	500 μV	310 μV	600 μV	-	5.3 mV	-	7.3 mV
CS16X2	50 μV	130 μV	90 μV	660 μV	440 μV	830 μV	-	7.3 mV	-	10.5 mV

¹ Dynamic Parameters for 10 MHz frequency acquired with 25 MHz low-pass filters activated. For 70 MHz frequency, no filters activated.

TIME-DOMAIN SAMPLING

Internal Sampling Rates: 200 MS/s, 100 MS/s, 50 MS/s, 25 MS/s, 10 MS/s, 5 MS/s, 2 MS/s, 1 MS/s,
(Maximum is model dependent) 500 kS/s, 200 kS/s, 100 kS/s, 50 kS/s, 20 kS/s, 10 kS/s, 5 kS/s, 2 kS/s, 1 kS/s

Internal Sampling Rate Accuracy/Stability¹: 1 part-per-million

Channel-to-Channel Skew²: <400 picoseconds

CLOCK IN

Clock In Signal Level: Minimum 0.3 V RMS

Maximum 1.5 V RMS

Clock In Signal Input Termination: 50 Ω

Clock In Signal Input Coupling: AC

Clock In Signal Duty Cycle: 50% \pm 5%

Clock In Modes:

1. External Clock – Input signal is used as a sampling clock signal and directly clocks Razor ADC chips
2. 10 MHz Reference – High accuracy 10 MHz input signal disciplines the internal sampling oscillator so that, for example, a 200 MS/s sampling rate is at exactly 20X the 10 MHz reference frequency

Maximum External Clock Frequency: Maximum Razor sample rate

Minimum External Clock Frequency: 10 MHz

10 MHz Reference Mode Frequency: 10 MHz \pm 10 kHz

CLOCK OUT

Clock Out Modes: Sampling Clock Out and 10 MHz Reference Clock Out

Clock Out Signal Level: 0-1.8 V

Clock Out Signal Output Termination: 50 Ω compatible

Maximum Clock Out Signal Frequency: Maximum Razor model sample rate

Minimum Clock Out Signal Frequency: 10 MHz (Using External Clock)

1 kHz (Using Internal Sampling)

Clock Out Signal Duty Cycle: 50%

1 Master Sampling Oscillator is disciplined by an on-board temperature-compensated 10 MHz reference signal with 1 part-per-million accuracy and stability.

2 Channels use same input settings

TRIGGERING

Trigger Source:	Any Input Channel, External Trigger or Software
Trigger Level:	Software controllable analog Trigger level with span of the Full Scale Input Range (FSIR) of the Trigger Source. Adjustable in ½ % steps
Trigger Slope:	Positive or Negative (software-selectable)
Trigger Engines:	2 per Input Channel, 1 for External Trigger -results logically ORed to create trigger event
Trigger Jitter ¹ :	1 Sample
Trigger Hold-off:	Allows triggers to be ignored in order to ensure acquisition of any pre-set amount of pre-trigger data.
Trigger Delay:	Allows suppression of the acquisition of any amount of post-trigger data in order to conserve memory for the acquisition of only later waveform data.

INTERNAL TRIGGERING

Trigger Sensitivity: ²	±2% of Full Scale Input Range of Trigger Source
Trigger Level Accuracy:	Better than ±2% of Full Scale

EXTERNAL TRIGGERING

External Trigger Input Voltage Ranges:	±1 V, ±5 V (software-selectable)
External Trigger Coupling:	AC or DC (software-selectable)
External Trigger Input Impedance:	2 kΩ
External Trigger Input Bandwidth:	>100 MHz
External Trigger Absolute Max Input:	±15 V
External Trigger Sensitivity:	±5% of Full Scale External Trigger Range
External Trigger Level Accuracy:	±10% of Full Scale External Trigger Range

¹ This jitter applies for an asynchronous trigger and sampling clock. Sub-nanosecond jitter may be achieved using synchronous trigger and sampling clock

² Signal amplitude must be at least 4% of Full Scale Input Range of Trigger Source to cause a trigger event. Smaller signals are rejected as noise.

COMPUSCOPE ACQUISITION

ACQUISITION MODES:

1. Single Record Mode – In Single Record Mode, each waveform is downloaded to PC RAM, where it is accessible to the user, prior to the next waveform acquisition.
2. Multiple Record Mode – In Multiple Record Mode, acquired waveforms are stacked in on-board Compscope memory for later download. Between successively triggers, the acquisition circuitry is rapidly re-armed in hardware with no software communication required.

Segment Memory is the amount of memory available to hold waveform data, which may include both pre- and post-trigger data

Post-Trigger Data: 32 Sample minimum up to full Segment Memory. Post-trigger Depth may be increased in steps of 32 Samples.

Pre-Trigger Data: Up to full Segment Memory.

MAXIMUM SEGMENT MEMORY

Single Record Mode^{1,2}:

Max Segment Memory \approx Total on-board memory / Number of Active Channels

Multiple Record Mode²:

Segment Memory \approx Total on-board memory / Number of Active Channels / Number of Segments

1 Number of Active Channels may be 1, 2 or 4.

2 The equation is not exact due to storage of a small amount of inter-record data, such as Time-Stamping Information.

SINGLE RECORD MODE ACQUISITION

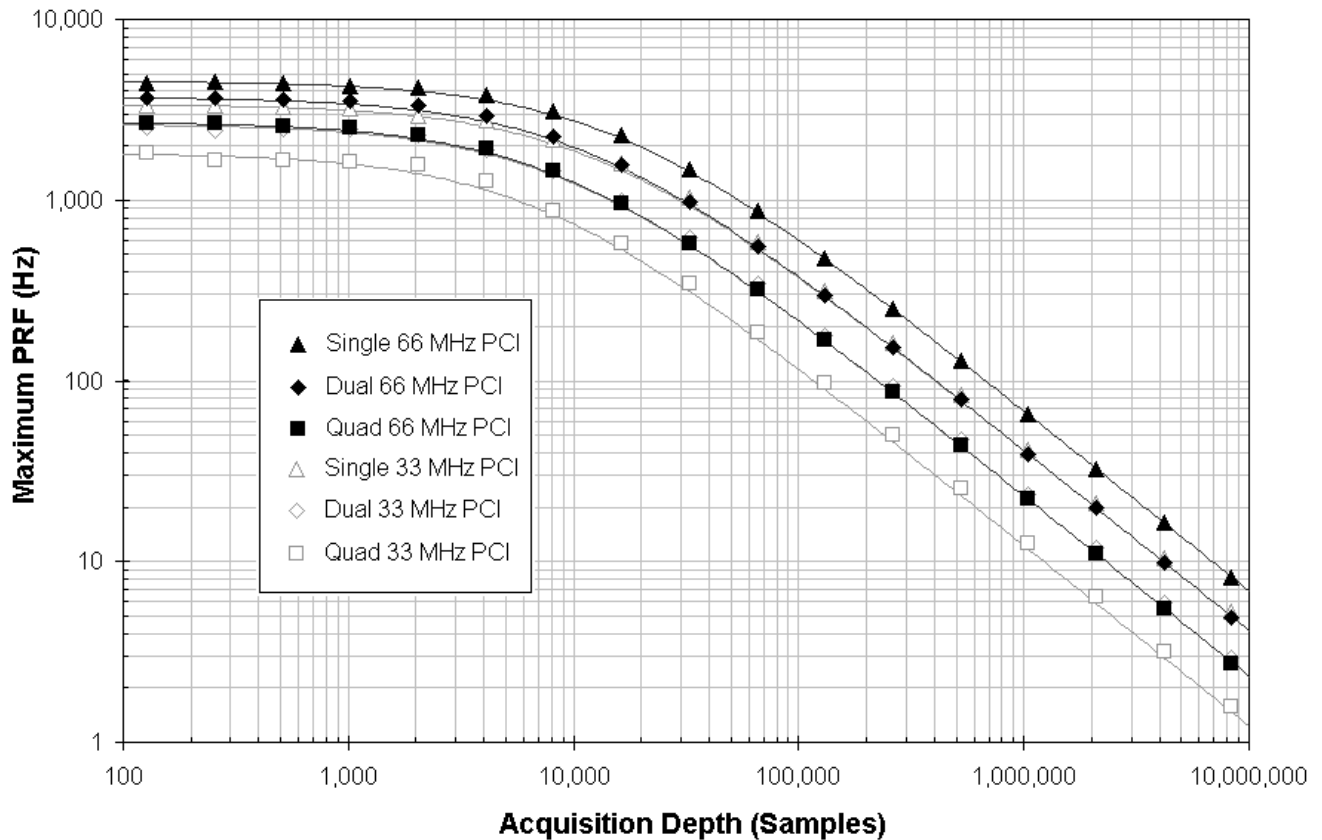

Razor's Repetitive Waveform Acquisition Performance

The plot above shows the Razor's maximum Pulse Repeat Frequency (PRF) which is the maximum trigger rate without trigger loss. Curves are shown with a sampling rate of 200 MS/s for acquisition of 1, 2 and 4 channels (Single, Dual and Quad) and for PCI clock speeds of 33 MHz and 66 MHz. (In practice, 66 MHz PCI usually implies PCI-X). Straight line portions of the curves at high Depths provide measurement of PCI bus-mastering transfer speeds of over 100 Megabytes/second and 200 Megabytes/second respectively for 33 MHz and 66 MHz PCI. Measurements on PCI Express models to be announced.

No data processing or storage to hard drive were performed for the PRF measurements and performance may vary slightly with system configuration.

MULTIPLE RECORD MODE ACQUISITION

Multiple Record Inter-Trigger Re-arm time: Less than 2 microseconds

Note: Because the no software communication is required during a Multiple Record acquisition, the Re-arm time is completely deterministic or invariant. For example, an acquisition of duration 6 microseconds could be triggered at a rate of up to $1/(6 \mu s + 2 \mu s) = 125 \text{ kHz}$ with a guarantee of no loss of triggers.

TRIGGER TIME-STAMPING

The Trigger Time –Stamping functionality tags the occurrence time of trigger events using a wide high–speed on-board counter that has high accuracy and is independent of any Host PC timing.

Time–Stamping Counter Clock source:	Fixed 133 MHz on-board oscillator or Sampling Clock (software-selectable)
Time–Stamping Counter Resolution:	One clock cycle
Time–Stamping Counter Width:	44-bits
Time–Stamping Counter Rollover time ¹ :	24 hours or more

MULTI-COMPUSCOPE SYSTEMS

Master/Slave CompuScope Mode

Number of Master/Slave CompuScopes:	2-8 cards
Board-to-Board Timing Skew:	<500 picoseconds

Note: In a Master/Slave CompuScope system, identical CompuScopes are configured to behave from a hardware and software perspective as a single multi-channel digitizer system. All CompuScopes within a Master/Slave system will sample, trigger and re-arm simultaneously. CompuScopes self-configure as a Master/Slave system upon detection of the internal Master/Slave inter-CompuScope bridge-board connector. This system may be broken up into independent CompuScopes simply by not installing the bridge-board.

Independent CompuScope Mode

Number of Independent CompuScopes: Number limited only by number of slots in backplane and available DC power.

Note: Users may install independent CompuScopes, which may be different models, within a single host PC. Independent CompuScopes may trigger and sample asynchronously. Independent asynchronous Compscope operation is fully supported by GageScope and all Compscope Software Development Kits (SDKs).

POWER CONSUMPTION

PCI DC SUPPLY	CS1621	CS1641	CS1622	CS1642
+5 V	12.7 W	22.3 W	12.7 W	22.3 W
+3.3 V	8.3 W	8.9 W	9.4 W	10.1 W
+12 V	0.3 W	0.2 W	0.2 W	0.2 W
-12 V	0	0	0	0
-5 V	0	0	0	0
Total	21.3 W	31.4 W	22.3 W	32.6 W

Note: The consumption values above are for Razor CompuScopes with the base acquisitions memory of 128 MegaSamples. For a 2 GigaSample Razor Compscope, the extra power consumption is 3 Watts. For intermediate memory options, the extra consumption increases in proportion to the amount of memory.

¹ At the top Razor Time-Stamping Counter clocking rate of 200 MHz, the counter rollover time is $2^{44}/200 \text{ MHz} = 87961 \text{ seconds} > 1 \text{ day}$.



HOST PC SYSTEM REQUIREMENTS

PCI-based computer, minimum Pentium II 500 MHz, with at least one free full-length PCI Express (8 or 16 lane) or PCI slot, 128 MB RAM, 200 MB of free hard disk space.

Operating System:

Windows 7:	All Versions (32/64-bit)
Windows Vista:	All Versions (32/64-bit)
Windows XP:	SP1 or higher (32/64-bit)
Windows Server:	2003, 2008
Linux Version:	Debian 5

SOFTWARE SUPPORT

Application Software:

GageScope is a Windows-based software for programming-free CompuScope operation

GageScope LITE Edition: Included with purchase, provides basic functionality

GageScope Standard Edition: Provides limited functionality of advanced analysis tools, except for Extended Math

GageScope Professional Edition: Provides full functionality of all advanced analysis tools

Software Development Kits:

CompuScope SDKs for C/C# for Windows

Includes: CompuScope C SDK for Windows¹
CompuScope .NET SDK for Windows²

CompuScope SDK for MATLAB for Windows

CompuScope SDK for LabVIEW for Windows

Linux support available.

FIRMWARE SUPPORT

eXpert Signal Averaging Firmware Option

Call factory for custom eXpert Signal Processing Firmware

OPERATING TEMPERATURE

Internal PC Temperature Range: 0 °C to +50 °C

¹ C SDK is compatible with LabWindows/CVI 7.0 +

² .NET SDK is CLR compliant and includes support for Visual Basic .NET and Delphi



WARRANTY

One year parts and labor

Certificate of NIST Traceable Calibration is included.

*All specifications subject to change without notice.

ORDERING INFORMATION

Hardware & Upgrades

Razor 16-bit Family	PCI CompuScopes		PCI Express CompuScopes	
	2 Channel	4 Channel	2 Channel	4 Channel
100 MS/s	CS1621: RAZ-002-100	CS1641: RAZ-004-100	CSE1621: RZE-002-100	CSE1641: RZE-004-100
200 MS/s	CS1622: RAZ-002-200	CS1642: RAZ-004-200	CSE1622: RZE-002-200	CSE1642: RZE-004-200
	Memory Upgrade: 128 MS to 256 MS	RAZ-181-001	Memory Upgrade: 1 GS to 2 GS	MEM-181-001
	Memory Upgrade: 128 MS to 512 MS	RAZ-181-003	Memory Upgrade: 1 GS to 4 GS	MEM-181-003
	Memory Upgrade: 128 MS to 1 GS	RAZ-181-005	Memory Upgrade: 1 GS to 8 GS	MEM-181-005
	Memory Upgrade: 128 MS to 2 GS	RAZ-181-007	Memory Upgrade: 1 GS to 16 GS	MEM-181-007

Cables

Set 1 Cable SMA to BNC ACC-001-031

Set 4 Cable SMA to BNC ACC-001-033

Master Multi-Card Upgrade RAZ-181-002

Slave Multi-Card Upgrade RAZ-181-003

eXpert™ Firmware Options

eXpert Signal Averaging Firmware Option 250-181-001

GageScope® Software

GageScope: Lite Edition Included

GageScope: Standard Edition (with Purchase of CompuScope Hardware) 300-100-351

GageScope: Professional Edition (with Purchase of CompuScope Hardware) 300-100-354

Software Development Kits (SDKs)

GaGe SDK Pack on CD 200-113-000

CompuScope SDK for C/C# 200-200-101

CompuScope SDK for MATLAB 200-200-102

CompuScope SDK for LabVIEW 200-200-103

eXpert Data Streaming (PCI Express Only) STR-181-000

900 N. State St.
Lockport, IL 60441-2200

Toll-Free (US and Canada):

phone 1-800-567-4243

fax 1-800-780-8411

Direct:

phone +1-514-633-7447

fax +1-514-633-0770

Email:

prodinfo@gage-applied.com

To find your local sales representative or distributor or to learn more about GaGe products visit:

www.gage-applied.com

Updated June 15, 2011

Copyright © 2011 Gage Applied Technologies. All rights reserved.