

NOT TO SCALE

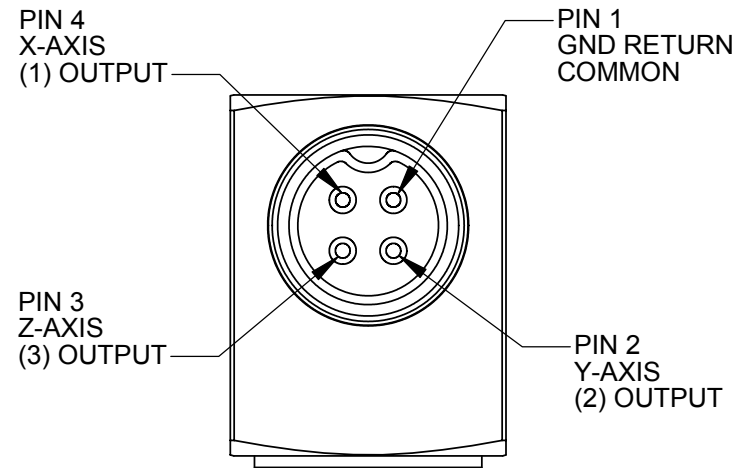

- 4. SENSITIVITY: 10mV/g NOMINAL
- 3. WEIGHT: 4 GRAMS
- 2. ARROWS INDICATE ACCELERATION DIRECTION FOR POSITIVE OUTPUT
- 1. MATERIAL: TITANIUM ALLOY

<b>DYTRAN</b>		INSTRUMENTS, INC.		CHATSWORTH, CA	
SCALE	4:1	REV	DATE	ECN	
DATE	5/14/2003	PART NO.			
DRAWN	PML	CHECKED		MATERIAL	
APPROVED		NEXT ASSEMBLY			
TITLE				DWG NO.	
OUTLINE / INSTALLATION DRAWING, MODEL 3023A1				127-3023A1	
				SHEET 1 OF 1	

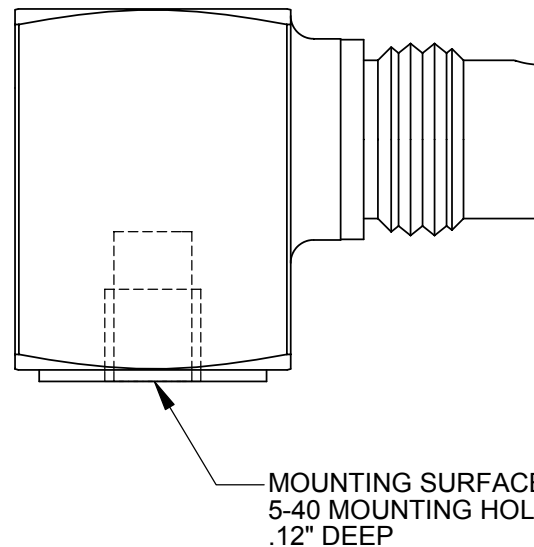
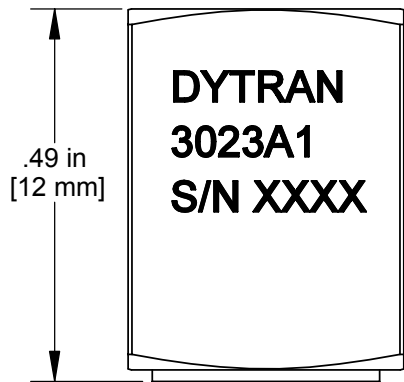

**SPECIFICATIONS, MODEL 3023A1 TRIAXIAL ACCELEROMETER**

<b>SPECIFICATIONS</b>	<b>VALUE</b>	<b>UNITS</b>
<b>PHYSICAL</b>		
WEIGHT	4	GRAMS
SIZE (HEIGHT x WIDTH x DEPTH)	0.49 x .36 x .36	INCHES
MOUNTING	5-40 TAPPED HOLE IN BASE	
CONNECTOR	4-PIN [1]	
MATERIAL, HOUSING/CONNECTOR	TITANIUM ALLOY	
<b>PERFORMANCE</b>		
SENSITIVITY, -10 +15% [2]	10.0	mV/G
RANGE, F.S. (each axis)	+/- 500	G
FREQUENCY RESPONSE, +/- 10%	2 to 10000	Hz
ELEMENT NATURAL FREQUENCY, NOM.	40	kHz
EQUIVALENT ELECTRICAL NOISE	.007	G, RMS
LINEARITY [3]	1	%F.S.
TRANSVERSE SENSITIVITY, MAX.	5	%
SIGNAL POLARITY	POSITIVE FOR MOTION IN DIRECTION OF ARROWS ON HOUSING	
<b>ENVIRONMENTAL</b>		
MAXIMUM VIBRATION	+/- 600	G
MAXIMUM SHOCK	5000	G
TEMPERATURE RANGE	-60 to +250	°F
ENVIRONMENTAL SEAL	HERMETIC	
COEFFICIENT OF THERMAL SENSITIVITY	.03	%/°F
<b>ENVIRONMENTAL</b>		
SUPPLY CURRENT RANGE, (each axis) [4]	2-to 20	mA
COMPLIANCE (SUPPLY) VOLTAGE RANGE (each axis)	+18 to +30	VDC
OUTPUT IMPEDANCE, TYP.	100	OHMS
OUTPUT BIAS VOLTAGE, NOM.	+10	VDC
DISCHARGE TIME CONSTANT, NOM.	0.5	SEC
GROUND ISOLATION	CASE GROUNDED	

[1] Connector mates with Dytran cable assy. Model 6811Axx. (xx = length in feet)

[2] Reference sensitivity measured at 100 Hz, 1 G RMS per ISA RP 37.2

[3] Linearity is % of specified full scale (or any lesser full scale range), zero-based best fit straight line method.

[4] Power only with Dytran LIVM power unit or other Dytran-compatible constant current type power unit. If power is applied without current limiting protection, the internal amplifier will be immediately destroyed.