

3. MATERIAL: HOUSING & CONNECTOR - 316L STAINLESS STEEL.
2. MOUNTING TORQUE - 15 LB.-IN.
1. WEIGHT - 6.8 GRAMS

EXCEPT AS OTHERWISE NOTED

ALL DIMENSIONS IN INCHES
TOLERANCE: .XXX = ± .xx = ± .01

SURFACE FINISH EXCEPT AS NOTED ✓

BREAK EDGES TO DEBURR RADIUS OR CHAMFER

△ THESE DIAS ⊙ TO T.I.R.

FILLETS - MAX RAD.

		<h1>MASTER ONLY IF IN RED</h1>		CHATSWORTH, CA.	
SCALE	4X	REV	A	DATE	1/29/07
DATE	12/7/95	PART NO.	-		
DRAWN	N.C.	CHECKED	CES		
APPROVED	CES 1.29.07		MAT'L	-	
TITLE			NEXT ASSEMBLY	-	
OUTLINE/INSTALLATION DRAWING, MODEL SERIES 3030B5H				USED ON	SERIES 3030B5H
				DWG NO.	127-3030B5H
				SHEET	1 OF 1

Model Number 3030B5H	PERFORMANCE SPECIFICATION	DOC NO PS3030B5H
--------------------------------	----------------------------------	----------------------------

	MINIATURE IEPE ACCELEROMETER	REV A, ECN 6388, 11/05/09
--	-------------------------------------	---------------------------



- **MINIATURE SIZE**
- **EXCELLENT LINEARITY**
- **HERMETICALLY SEALED**
- **HIGH OPERATING TEMPERATURE**

PHYSICAL

Weight
Size
Connector
Mounting Provision
Material
Element Style

Hex x Height
Top Mounted
Integral Stud
Accelerometer and Connector

ENGLISH		SI	
0.24	oz	6.8	grams
0.375 x 0.67	Inches	9.525 x 17.01	mm
10-32 Micro Coax		10-32 Micro Coax	
10-32 (UNF-2A)		10-32 (UNF-2A)	
		304L	
Quartz Shear		Quartz Shear	

PERFORMANCE

Sensitivity, ±5% [1]
Range F.S for ± 5 Volts Output
Frequency Response, ±5%
Resonant Frequency, Nom
Equivalent Electrical Noise Floor
Linearity [2]
Maximum Transverse sensitivity
Strain Sensitivity @ 250µε

10	mV/g	1	mV/m/s ²
±500	g	±4905	m/s ²
5 to 10000	Hz	5 to 10000	Hz
30	kHz	30	kHz
0.0036	Grms	0.0353	m/s ² rms
± 1%	% F.S.	± 1%	% F.S.
5	%	5	%
0.003	g/µε	0.03	m/s ² /µε

ENVIRONMENTAL

Maximum Vibration
Maximum Shock
Temperature Range
Seal, Hermetic

±1000	Gpeak	±9810	m/s ² peak
±3000	Gpeak	±29430	m/s ² peak
-60 to +325	*F	-54 to 163	*C
Welded/Glass To Metal		Welded/Glass To Metal	

ELECTRICAL

Supply Current Range [3]
Compliance Voltage Range
Output Impedance, Typ
Bias Voltage
Discharge Time Constant

2 to 20	mA	2 to 20	mA
+ 18 to +30	Volts	+ 18 to +30	Volts
100	Ω	100	Ω
7.5 to 9.5	VDC	7.5 to 9.5	VDC
0.1 to 0.15	Sec	0.1 to 0.15	Sec

This family also includes:

Model	Sensitivity (mV/g)	Frequency Response (Hz)	Time Constant (Sec)	Operating Temp (*F)
3030B4	10	2 to 10000	0.5 to 1	-60 to 250
3030B5	10	5 to 10000	0.1 to 0.15	-60 to 250

Please refer to the performance specifications of the products in this family for detailed description

Supplied Accessories:

- 1) Accredited calibration certificate (ISO 17025)

Notes:

- [1] Measure at 100Hz, 1 Grms per ISA RP 37.2
- [2] Measure using zero-based straight line method, % of F.S. or any lesser range.
- [3] Do not apply power to this system without current limiting, 20 mA MAX. To do so will destroy the IC charge amplifier.

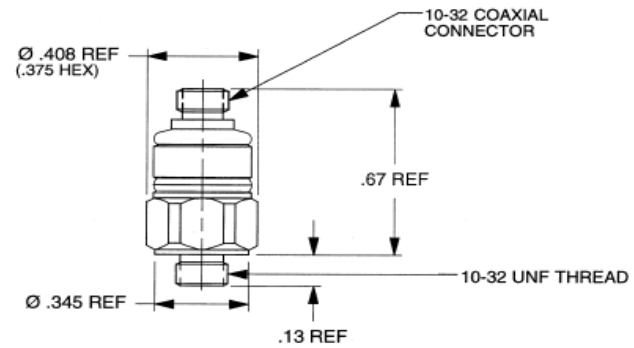
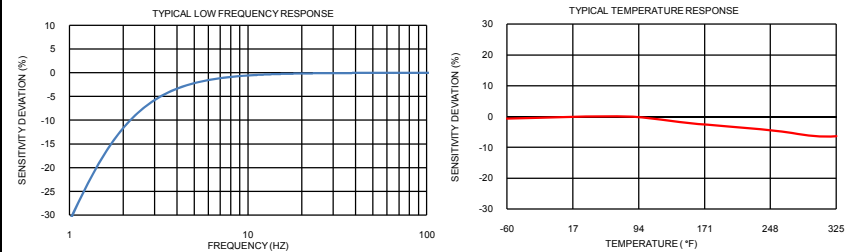

Units on the line drawing are in inches, units in brackets are in millimeters. Refer to 127-3030B5H for more information.



21592 Marilla Street, Chatsworth, California 91311 Phone: 818.700.7818 Fax: 818.700.7880 www.dytran.com
For permission to reprint this content, please contact info@dytran.com