

STANDARD #8 OR M4 BOLT

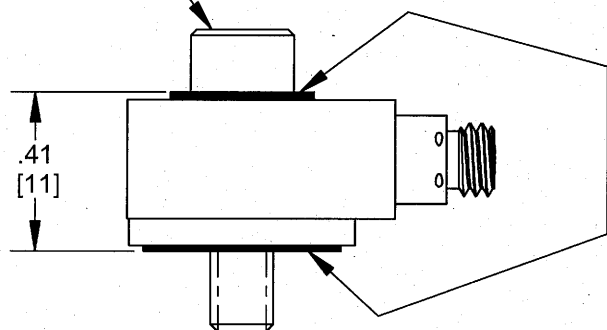

HARD ANODIZED ELECTRICALLY ISOLATED SURFACES

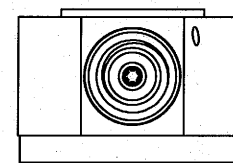

3211A1: 10mV/g

3211A2: 100mV/g

EXCEPT AS OTHERWISE NOTED	
ALL DIMENSIONS IN INCHES TOLERANCE: XXX = ± .005 XX = ± .01	
SURFACE FINISH EXCEPT AS NOTED \checkmark 63	
BREAK EDGES TO DEBURR .005 / .015 RADIUS OR CHAMFER	
FILLETS: .005 MAX R	

DYTRAN

INSTRUMENTS, INC.

CHATSWORTH, CA

SCALE 2:1	REV -	DATE -	ECN -
DATE 4/1/2005	PART NO. MODEL 3211A		
DRAWN PML	CHECKED	MATERIAL	
APPROVED PML 12.905	NEXT ASSEMBLY		USED ON
TITLE OUTLINE / INSTALLATION DRAWING MODEL 3211A ACCELEROMETER			DWG NO. 127-3211A
SHEET 1 OF 1			

PERFORMANCE SPECIFICATION

ENGLISH VERSION

DYTRAN **3211A1**

Rev A ECN4953
12/1/2007

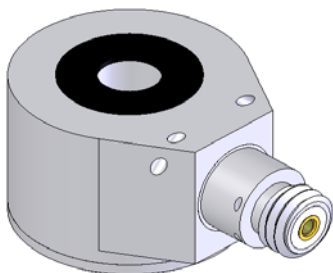

ACCELEROMETER, SINGLE AXIS IEPE

		units	minimum	typical	maximum
PHYSICAL					
Weight		grams		9.6	
Size	Diameter	inch		0.6	
	Height	inch		0.42	
Mounting	Thru hole		accommodates standard 8-32 or M4 bolt		
Connector	Type			coaxial	
	Thread			10-32	
Housing	Location			side	
	Material			titanium alloy	
	Isolation		case connected to signal ground and isolated from mounting surface by integral isolation washers		
Sensing Element	Material			ceramic	
	Mode			shear	
PERFORMANCE					
Sensitivity at 4mA		mV/g	9.5	10	10.5
Measurement Range		±gpk		500	
Frequency Range, ±5%		Hz	1		10000
Resonance Frequency		kHz		38	
Equivalent Noise	1Hz to 10kHz	g rms		0.0005	
Sensitivity vs Current	2mA to 10mA	%			1
Transverse Sensitivity		%			5
Polarity	see outline drawing			positive	
ENVIRONMENTAL					
Shock		g pk			5000
Operating Temperature		°F	-67		250
Seal				hermetic	
Coefficient of Thermal Sensitivity		%/°F		0.06	
Magnetic Sensitivity at 100 Gauss		g/Gauss		0.004	
Thermal Shock Sensitivity		g/°F		0.02	
Base Strain Sensitivity		g/με		0.04	
Stray Voltage Sensitivity	10V applied to mounting surface	equiv. g			0.004
ELECTRICAL					
Supply Current		mA	2		20
Compliance Voltage		Vdc	18		30
Output Bias	Room Temp	Vdc	11		13.5
	Operating Temp	Vdc	8		16
Output Impedance		Ω		120	
Discharge Time Constant		sec		0.5	
Warmup Time		sec		2	

ACCESSORIES SUPPLIED

(1) 6595, 8-32 mounting screw