

PROPRIETARY AND CONFIDENTIAL

THE INFORMATION CONTAINED IN THIS DRAWING IS THE SOLE PROPERTY OF DYTRAN INSTRUMENTS INC. ANY REPRODUCTION IN PART OR AS A WHOLE WITHOUT THE WRITTEN PERMISSION OF DYTRAN INSTRUMENTS, INC. IS PROHIBITED

REVISIONS

REV	ECN	DESCRIPTION	BY/DATE	CHK	APPR
A	6816	INITIAL RELEASE	RT 06/04/10	<i>DV</i>	<i>AUS</i>

MODEL	SENSITIVITY
3221C	10 pC/G ±15%
3221C2	5 pC/G ±15%

ANODIZED ALUMINUM WASHERS
MOUNTING ASSEMBLY 6297 MODEL (SUPPLIED)

SHRINK TUBING

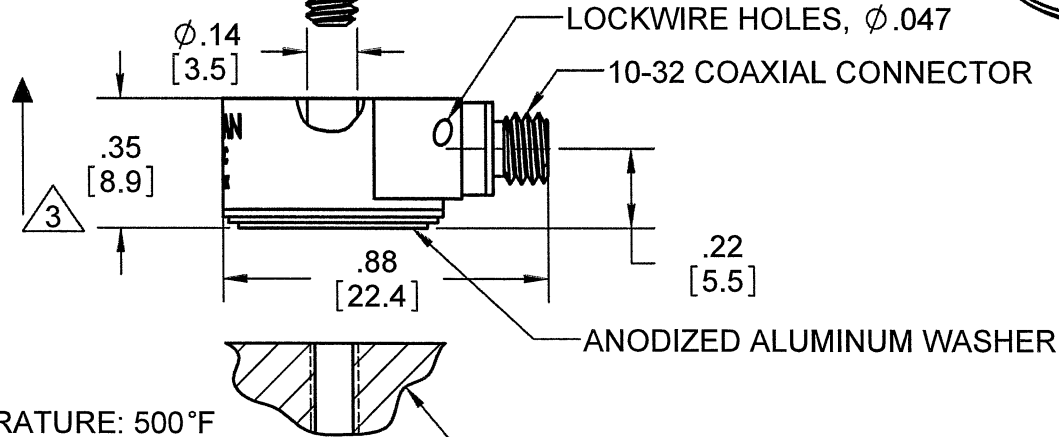
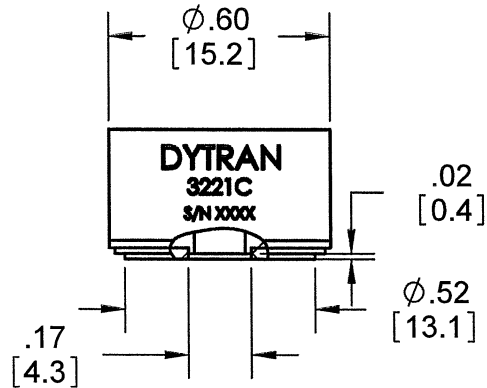
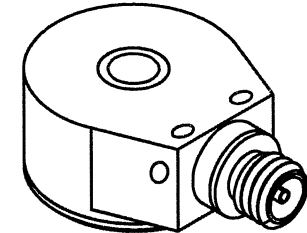

MOUNTING RECOMMENDATIONS:
CLEAN SURFACE AT LEAST $\phi .55$, FLAT TO $.0001$ TIR
TAP 6-32 UNC-2B AT LEAST $\nabla .13$
USE SILICON GREASE, TORQUE TO 5-7LB-IN

5. MAXIMUM OPERATING TEMPERATURE: 500°F
4. MATERIAL: HOUSING - 304L/CONNECTOR - KOVAR
3. DIRECTION OF ACCELERATION FOR POSITIVE OUTPUT
2. SENSITIVITY: SEE TABLE
1. WEIGHT, MAX: 12.5 GRAMS

NOTES: UNLESS OTHERWISE SPECIFIED

CONTRACT NO.



TITLE:
OUTLINE/INSTALLATION DRAWING, MODEL 3221C

USED ON	NEXT ASSY	UNLESS OTHERWISE SPECIFIED: INTERPRET DIM & TOL PER ASME Y14.5M - 1994. REMOVE BURRS. COUNTERSINK INTERNAL THDS 90° TO MAJOR DIA. CHAM EXT THDS 45° TO MINOR DIA. THD LENGTHS AND DEPTHS ARE FOR MIN FULL THDS. THDS PER MIL-S-7742. DIMENSIONS APPLY AFTER FINISHING.
APPLICATION		
THIRD ANGLE PROJECTION USA		ALL MACHINED SURFACES. \checkmark TOTAL RUNOUT WITHIN $.005$. BREAK SHARP EDGES $.005$ TO $.010$. MACHINED FILLET RADII $.005$ TO $.015$. WELDING SYMBOLS PER AWS A2.4. ABBREVIATIONS PER MIL-STD-12.

UNLESS OTHERWISE SPECIFIED: DIMENSIONS ARE IN INCHES. DIMENSIONS IN BRACKETS [] ARE IN MILLIMETERS TOLERANCES ARE: INCHES METRIC ANGLES .XX ± .03 .X ± 0.8 ± 1° .XXX ± .010 .XX ± 0.25		
MATERIAL	APPROVALS	DATE
FINISH	ORIG	DV 08/14/09
DO NOT SCALE DRAWING	CHK	<i>DV</i> 6/24/10
	APP	<i>AUS</i>

SIZE	CAGE CODE	DWG. NO.	REV
A	2W033	127-3221C	A
SCALE: 2:1	SOLIDWORKS	SHEET 1 OF 1	

MODEL NUMBER 3221C	PERFORMANCE SPECIFICATION	DOC NO. PS3221C
CHARGE MODE ACCELEROMETER		REV A, ECN6816, 06/04/10

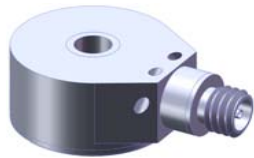

- **MINIATURE SIZE**
- **HIGH TEMPERATURE OPERATION**
- **HERMETICALLY SEALED**

PHYSICAL

Weight, Max
Mounting Provision
Connector [2]
Case Material
Sensing Element Type

ENGLISH		SI	
0.44	oz	12.5	grams
Ø.140 THRU HOLE		Ø.140 THRU HOLE	
10-32		10-32	
304L		304L	
Piezoceramic		Piezoceramic	

PERFORMANCE

Sensitivity, +/-15% [3] [4]
Range F.S.
Frequency Response, +/- 10%
Mounted Resonant Frequency
Amplitude Non-Linearity
Transverse Sensitivity, Max
Strain Sensitivity @250/μσ

10	pC/g	1.02	pC / m/s ²
+/-500	g	+/-4900	m/s ²
[5] to 10000	Hz	[5] to 10000	Hz
>40	kHz	>40	kHz
1	%F.S MAX	1	%F.S MAX
2	%	2	%
0.074	g/με	0.73	m/s ² /με

ENVIRONMENTAL

Maximum Vibration
Maximum Shock
Temperature Range
Environmental Seal

700	g rms	6860	m/s ² rms
5000	g	49000	m/s ²
-60 to +500	°F	-51 to + 260	°C
Hermetic		Hermetic	

ELECTRICAL

Output Signal Polarity
Case Grounding
Base Grounding

Positive	Positive
Case is grounded	Case is grounded
Base is isolated	Base is isolated

This family also includes:

Model	Sensitivity (pC/g)	Range F.S. (g)	Operating Temperature (°F)
3221C2	5	± 1000	-60 to +500

Please, refer to the performance specifications of the products in this family for detailed description.

Supplied Accessories

- 1) Model 6297 mounting assembly
- 2) Accredited calibration certificate (ISO 17025)

Notes:

- [1] Flat mounting surface for adhesive mount.
- [2] Connector , radially mounted, 10-32 coaxial.
- [3] Measured at 100 Hz, 1 G RMS per ISA RP37.2.
- [4] Actual sensitivity is on a calibration certificate supplied with each instrument.
- [5] Low frequency response is depend upon the discharge time constant of the charge amplifier.
- [6] Unit can survive a intermittent exposure to 600°F MAX
- [7] In the interest of constant product improvement, we reserve the right to change specifications without notice.

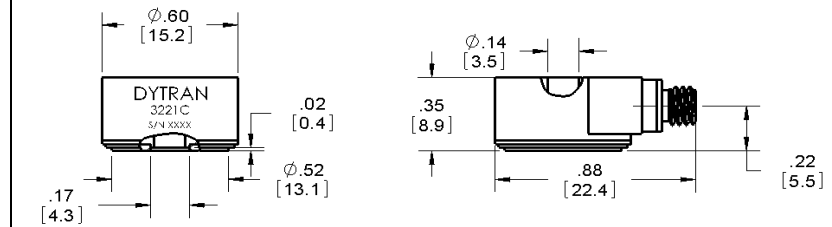
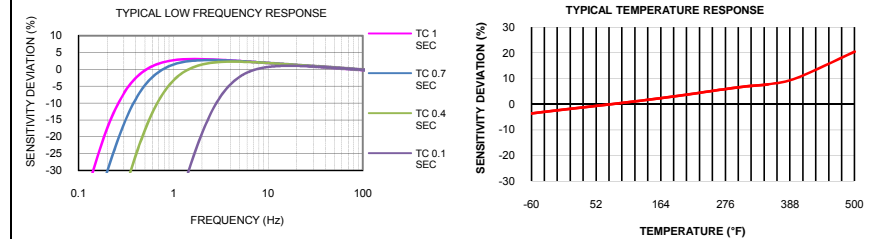

Units on the line drawing are in inches, units in brackets are in millimeters. Refer to 127-3221C for more information.



21592 Marilla Street, Chatsworth, California 91311 Phone: 818.700.7818 Fax:818.700.7880
www.dytran.com For permission to reprint this content, please contact info@dytran.com