

KEEPER, SUPPLIED
(REMOVE PRIOR TO USE)

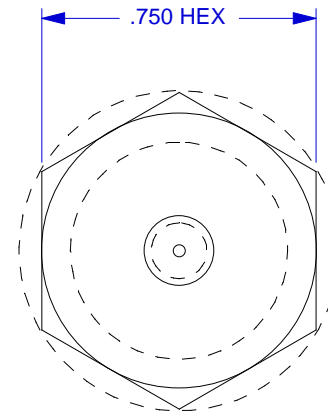
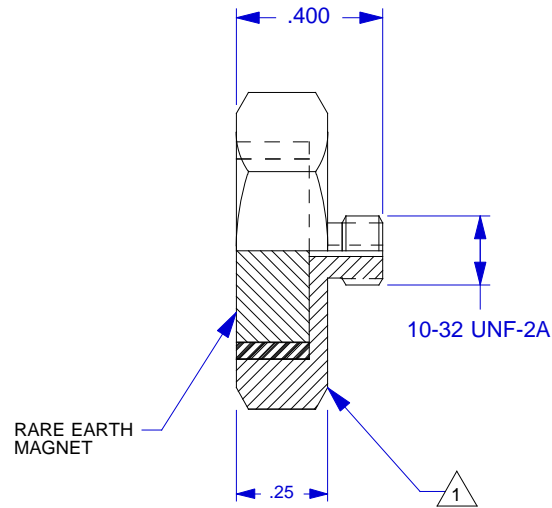

1 BODY MATERIAL: 17-4PH ST. STEEL

		CHATSWORTH, CA.					
SCALE	2X	REV	-	DATE	-	ECN	-
DATE	4/11/01	PART NO.	6196				
DRAWN	R.A.	CHECKED	N.C.		MAT'L	-	
APPROVED		NEXT ASSEMBLY	-		USED ON	6196	
TITLE						DWG NO.	
OUTLINE/INSTALLATION, BASE, MAGNET MODEL 6196						127-6196	
						SHEET 1 OF 1	