

MODEL.	MAT'L	WEIGHT
6240S	303 ST. STEEL	109.5 GRAMS
6240A	AL ALLOY 6061-T6	36.5 GRAMS

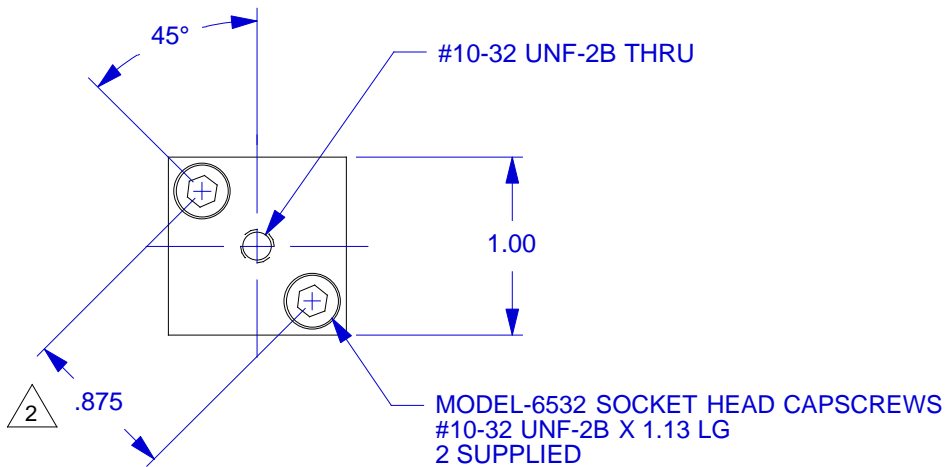

2 DRILL .159 DIA X .46 MIN DEEP ON MATING PART
TAP #10-32 UNF-2B X .38 MIN DEEP

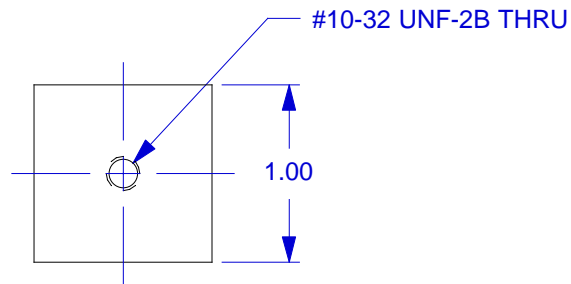
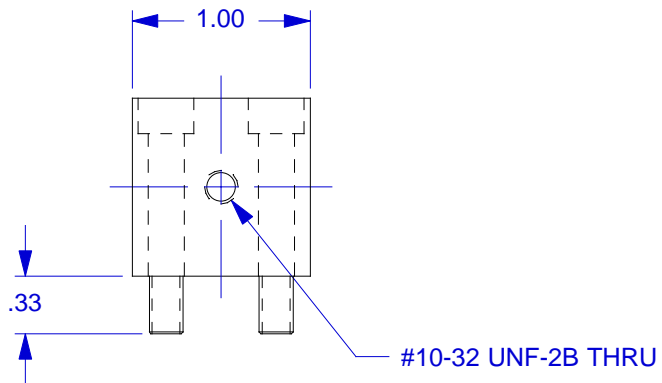

3 MODEL 6240A - FINISH: HARD ANODIZE, COLOR CLEAR.

2 DRILL MATING PART TO INDICATED DIMENSIONS

1. TORQUE 10-32 SOCKET HEAD CAPSCREWS
TO 16-18 LB.-IN.

IDYTRAN INSTRUMENTS, INC.		CHATSWORTH, CA.	
SCALE 2X	REV -	DATE -	ECN -
DATE 6/12/95	PART NO. -		
DRAWN D. Z.	CHECKED N. C.	MAT'L -	
APPROVED	NEXT ASSEMBLY	USED ON MODEL 6240	
TITLE OUTLINE/INSTALLATION DRAWING MOUNTING BLOCK, TRIAXIAL MODEL SERIES 6240		DWG NO. 127-6240	
SHEET 1 OF 1			